

Varimixer

KODIAK 20

Floor model

VERY SIMPLE INTUITIVE OPERATION Set the time and speed. Press start and stop. It's that simple, and everything is controlled at an ergonomic working height from the angled control panel.

ERGONOMIC RAISING AND LOWERING The ergonomically designed handle lowers and raises the bowl and locks it in place in a single movement.

FRONT ATTACHMENT DRIVE KODIAK is also available with an attachment drive for meat mincers and vegetable slicers.

PATENTED DETACHABLE SAFETY GUARD The guard has an integrated filling tray, is made of transparent polycarbonate and is dishwasher-safe. It can be attached instantly without tools. The guard is held in place by magnets, which also serve as a safety cut-off.

WORLD'S MOST EFFECTIVE TOOL Unique design increases speed at the periphery and reduces the working time.

TWO MACHINES IN ONE The KODIAK 20-litre model can be supplemented with a smaller 12-litre bowl and associated tools, for production in reduced quantities. This increases the machine's versatility.

ERGONOMIC BOWL TROLLEY No heavy lifting is needed when the bowl is wheeled directly to and from the machine at worktop height. The bowl can be tipped, but is seated securely in a rubber ring during movement.

IP44 FROM 2018 From 2018, Varimixer KODIAK can be cleaned in line with the IP44 standard.

STAINLESS STEEL Made of easy-to-clean stainless steel with a strong frame and high, adjustable legs, to allow cleaning under the machine. The bowl, wire whip, beater, dough hook and scraper are also made of stainless steel and are dishwasher-safe.

RUNS ON 230 VOLTS KODIAK can be connected to a normal power outlet. A frequency converter and a three-phase motor make Varimixer KODIAK a very powerful mixer.

HEIGHT-ADJUSTABLE LEGS



VARIMIXER KODIAK OPTIONS – MODELS



Stainless steel, 20 L floor



Marine version, Stainless steel, 20 L floor

OPTIONS – ATTACHMENT DRIVE



Attachment drive for meat mincer and vegetable cutter



Meat mincer, 70 mm



Meat mincer, 82 mm



Vegetable cutter GR20

VARIMIXER KODIAK STANDARD TOOLS – A-EQUIPMENT 20 L



Hook, whip, beater and bowl 20 L in stainless steel.

VARIMIXER KODIAK TOOLS – B-EQUIPMENT 20/12 L



Hook, whip, beater and bowl 20/12 L in stainless steel.

ACCESSORIES - TOOLS



Automatic scraper in stainless steel. Nylon or teflon blade. 20L and 20/12L.



Tool rack, 91 cm

VARIMIXER KODIAK 20L STANDARD

| |
|--|
| Stainless steel |
| 1 bowl 20 liter in stainless steel |
| 1 beater in stainless steel |
| 1 hook in stainless steel |
| 1 whip with stainless steel wires |
| Removable magnetic safety guard guard plastic – CE-certified |
| Digital timer and emergency stop |
| Voltage: 1 ph, 230V, 50-60 Hz. 700 W |

VARIMIXER KODIAK 20L STANDARD TECHNICAL DATA

| | |
|------------------------|--------------|
| Volume | 20 l |
| Effect | 700 W |
| Voltage* | 230 V |
| Net weight floor model | 154 kg |
| Variable speed | 64 - 353 RPM |
| Phases | 1 ph |
| IP code | IP44 |

*Other voltage power supply are available upon request in the range of 100 to 480 V. All standard and marine mixers are available in 50 and 60 Hz.

VARIMIXER KODIAK 20L MARINE VERSION

Water cover at air ventilation, slotted free screws, fixed sealed power cable, supplied without plug. Gasket at machine lid. Built in transformer. Complies with USPHS.

Voltage: 2 ph, 400V, 50-60 Hz with 0 and ground. 700 W
2 ph, 440V, 50-60 Hz with 0 and ground. 700 W
2 ph, 480V, 50-60 Hz with 0 and ground. 700 W

DIMENSIONS

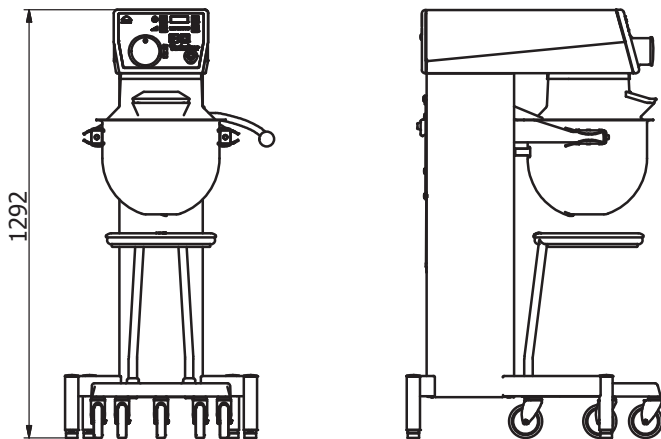

CAPACITIES

| | |
|-------------------------|---------|
| Egg Whites | 2.4 l |
| Whipped cream | 5.0 l |
| Mayonnaise | 16 l |
| Herb butter | 10 kg |
| Mashed potatoes | 12 kg |
| Bread dough (50% AR) | 10 kg |
| Bread dough (60% AR) | 11 kg |
| Ciabatta dough (70% AR) | 12 kg |
| Muffins | 14 kg |
| Layer cake base | 5.0 kg |
| Meatball mix | 15 kg |
| Icing | 14 kg |
| Doughnut (50% AR) | 12.5 kg |

CERTIFICATIONS

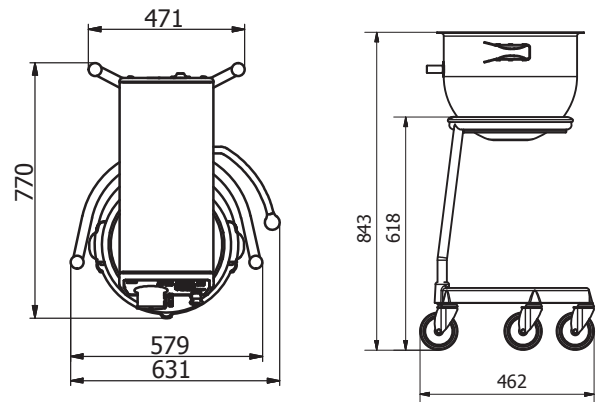

Varimixer

A/S Wodschow & Co
Kirkebjerg Søpark 6
DK-2605 Brøndby
P: +45 4344 2288
E: info@varimixer.com
www.varimixer.com