

GM

Professional Undercounter Glasswasher/Dishwasher – 450mm Rack W 500mm x D 555mm x H 860mm

The Washtech Professional Range combines the best of modern technology with an uncompromising use of high quality components and heavy duty stainless steel construction. The result is a machine that you can rely on for great wash results for many years to come.

The Washtech GM incorporates intuitive electronic controls providing soft wash start, the eco power saver system, easy to read temperatures for HACCP reporting, chemical pump adjustments and priming, cycle customisation, immediate fault diagnosis and much more. At just 500mm wide and equipped to wash glasses, cups and dishes, the compact and versatile GM packs a lot of punch for the smallest electronic machine in the Washtech range.

Standard Features

- Quikstart 1, 2 and 3 minute cycles
- Washes up to 960 glasses per hour / 840 plates per hour
- Compatible with 365mm to 450mm glass and dish racks
- QuikConnect Installation with everything you need including:
 - Water supply hose
 - Dual detergent and rinse aid pumps with injector lines
 - Drain pump outlet hose
 - 15 amp plugset
 - No commissioning required
- Reliable results through robust stainless steel wash and rinse arms with precision stainless jets
- Selectable cold rinse option
- Durable stainless steel construction
- Moffat's Comprehensive 5-2-1 Warranty
- Low hot water consumption of 2.2 litres per cycle
- Soft start ensures great wash results through progressively pressurising the cycle to provide a consistent and even clean every time
- EcoPower reduces temperatures and energy consumption when machine is not being used
- Insulated door to reduce the noise and heat from the machine
- Reliable double filtration system via scrap trays and separate wash inlet

Includes:

- 1x 600 70081 - 450mm dish rack
- 1x 600 70080 - 450mm cup rack
- 1x C660503 - cutlery container
- 1x 213 30001 - rack adapter



GM

Professional Undercounter Glasswasher/Dishwasher – 450mm Rack

W 500mm x D 555mm x H 860mm

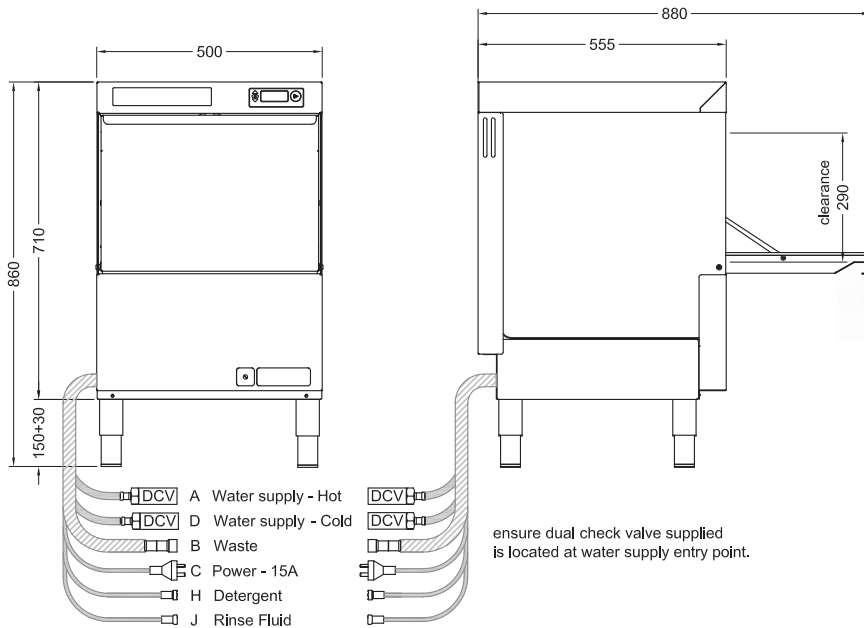

MOFFAT®

moffat.com.au

Australia
Moffat Pty Limited

Victoria/Tasmania
740 Springvale Road
Mulgrave, Victoria 3170
Telephone 03-9518 3888
Facsimile 03-9518 3833
vsales@moffat.com.au
www.moffat.com.au

New South Wales
Telephone 02-8833 4111
nswsales@moffat.com.au

South Australia
Telephone 03-9518 3888
vsales@moffat.com.au

Queensland
Telephone 07-3630 8600
qldsales@moffat.com.au

Western Australia
Telephone 08-9202 6820
bgarcia@moffat.com.au

A Hot Water	Temperature	65°C
	Connection	3/4" male hose supplied
	Pressure	200-350kPa
	Flow	20 litres per min
	Quality	Potable & soft
	Backflow Prevention	Dual Check Valve (DCV)
	Consumption	2.2 litres per cycle
B Waste	Connection	Hose supplied for 38mm open standpipe 750 high or connection to sink trap
C Electrical	Single phase	240V 50Hz 15A plugset supplied
	Maximum Power Consumption	
	Single phase	3.2kW
	Heating	
	Wash	2.5kW
	Rinse	3.0kW

Dimensions	Width	500mm
	Depth	555mm
	Height	860mm
	Weight	54kg

Packed Dimensions	Width	530mm
	Depth	620mm
	Height	830mm
	Weight	68kg
	Cubicmetres	0.27m ³

Water Quality Requirements	Hardness	ppm	pH
	Min	20	7
	Max	100	8

Ions	Cl ⁻	SO ₄	Fe	Mn	Cu	CL ₂
Max mg/l	100	400	0.1	0.5	0.05	0.1

Refer operator manual for installation instructions



ISO9001
All Washtech products are designed and manufactured by Washtech using the internationally recognised ISO9001 quality management system, covering design, manufacture and final inspection, ensuring consistent high quality at all times.

In line with policy to continually develop and improve its products, Washtech reserves the right to change specifications and design without notice.



© Copyright Moffat Ltd
Moffat / 11.16

an Ali Group Company



The Spirit of Excellence